

SOFINA AM-2015

Size 1200x900x2120mm

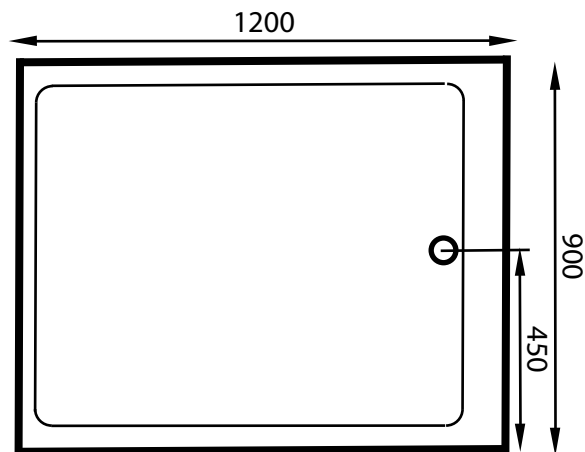
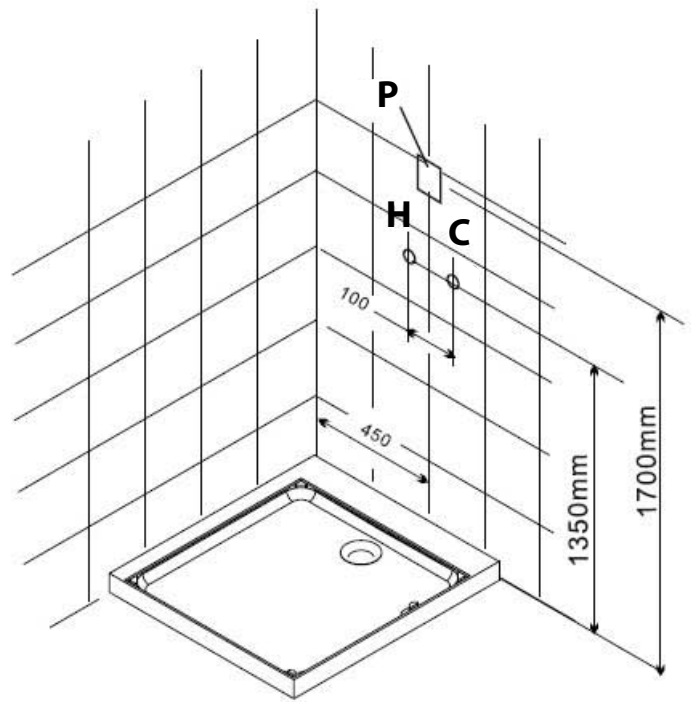
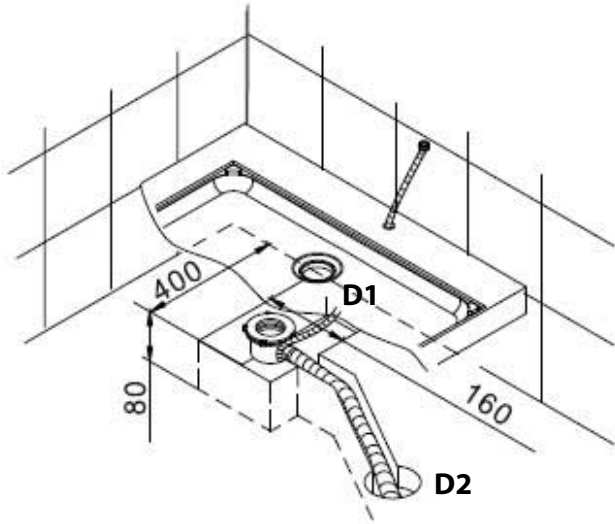

Key

- P = Power supply
 - H = Hot water feed
 - C = Cold water feed
 - D1 = Drainage
 - D2 = Drainage under ground
- All measurements are in mm.

Installation Requirements

Assembly

The shower is sectional and is delivered in several boxes; it will fit through standard doorways for assembly on site. This model is built in position on a fixed composite stone tray. You will need access around all exposed sides and above in order to assemble it.

Drainage

The unit has a low entry stone tray that requires that the trap and waste pipe (supplied) is fitted underneath your floor as shown in the plan above. However it's also possible to raise the shower on to a platform to create room for the drainage underneath.

Water Supply

The shower requires a supply of hot and cold water at a minimum of 1.5 bar of pressure. This can be achieved from a combination boiler/pressurised system or a pumped gravity/vented supply. Two braided flexible hot and cold supply pipes are provided with the shower. Please see the plan above for the suggested connection points for the hot and cold supply.

Ventilation

No additional ventilation is required beyond what is necessary for a conventional shower as required by building regulations. The roof contains the water vapour within the cabin and the steam can be condensed to waste just by turning on the shower after use.

Electrical Connection

A 3.2kw supply is required which should be connected through an appropriate RCD (residual current device) protected fused spur or consumer board. We also recommend that an isolation switch is installed to cut the power to the transformer that powers the low voltage ancillaries (radio lights etc.). It's essential that all electrical work is carried out by a fully qualified electrician or inspected before use.